

OPEN WELD HEADS

OSW



Item number



Open weld heads are clamped on one side of the weld joint. During welding, the gas- or water-cooled torch with hose package rotates around the tube.

- Robust design
- Extremely easy to use
- Option of using additional wire
- Stepless tube size range
- Torch bracket has 90° tilting function

OSW WELD HEADS

Five weld heads for the OD 8 – 273 mm tube size range

Weld head:	Tube size range mm	inch	Weight
OSW 40	OD 8 – 40 mm	0.315" – 1.575"	2 kg
OSW 80	OD 10 – 76.2 mm	0.394" – 3.000"	3 kg
OSW 115	OD 20 – 114.3 mm	0.787" – 4.500"	4.5 kg
OSW 170	OD 40 – 168.3 mm	1.575" – 6.626"	6.5 kg
OSW 275	OD 88.9 – 273 mm	3.500" – 10.748"	19 kg

In the case of the OSW 275, the rotor can be decoupled and the tongs can be rotated manually.

Package includes:

- Weld head
- Integrated start/stop button on the handle
- Top jaw
- OSW torch bracket (with roll scanning in the case of OSW 275)
- Mechanical headway control

Optional:

- OSW 40 WITH ANGULAR GEARBOX**
- OSW 80 WITH ANGULAR GEARBOX**
- OSW 115 WITH ANGULAR GEARBOX**
- OSW 170 WITH ANGULAR GEARBOX**



1.3.1001
1.3.1101
1.3.1201
1.3.1301
1.3.1401

Orbital welding systems

Welding tools

Welding accessories

Joint preparation

Purging accessories

Measuring devices

Service / general

Dimensions table for OSW open orbital weld heads

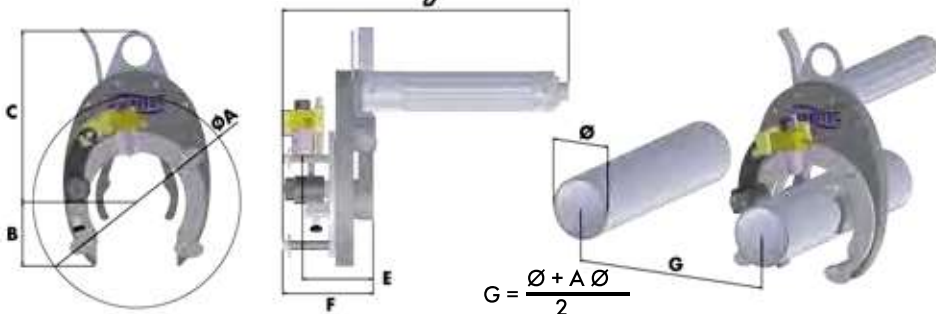

Weld head	Ø A		B		C		D		E		F	
	mm	inch	mm	inch	mm	inch	mm	inch	mm	inch	mm	inch
OSW 40	120	4.724	40	1.575	145	5.709	310	12.205	81	3.189	91	3.583
OSW 80	210	8.268	64	2.520	171	6.732	290	11.417	69	2.717	91	3.583
OSW 115	243	9.567	90	3.543	210	8.268	290	11.417	69	2.717	91	3.583
OSW 170	310	12.205	134	5.276	266	10.472	290	11.417	69	2.717	91	3.583
OSW 275	465	18.307	180	7.086	410	16.141	310	12.204	105	4.133	125	4.921

OPEN WELD HEADS



HOSE PACKAGES

Item number



BJ INTERCONNECTION CABLE, 8 m

1.3.1626



BJ INTERCONNECTION CABLE WITH WIRE OUTLET, 8 m

1.3.1629



TIG TORCH WITH HOSE PACKAGE, GAS- OR WATER-COOLED FOR OSW

'MINI' TIG TORCH with hose package, 8.5 m, gas-cooled, equipped with torch consumables and tungsten electrode Ø 1.6 mm

1.3.1602



'MINI' TIG TORCH with hose package, 6 m, water-cooled, equipped with torch consumables and tungsten electrode Ø 2.4 mm

1.3.1625



'STANDARD' TIG TORCH with BJ hose package, 8.5 m, gas-cooled, equipped with torch consumables and tungsten electrode Ø 2.4 mm

1.3.1631



'STANDARD' TIG TORCH with BJ hose package, 8.5 m, water-cooled, equipped with torch consumables and tungsten electrode Ø 2.4 mm

1.3.1634



SPARE 2.5 m silicone hose package, gas-cooled, for OSW 40
(Special tooling required)

1.1.1615

SPARE 2.5 m silicone hose package, gas-cooled, for OSW 80 – 275

1.3.1615



**EXTENSION HOSE PACKAGES FOR OSK / OSW
TURN AND RBK**

EXTENSION HOSE PACKAGE, 8 m, gas-cooled

1.3.2005

EXTENSION HOSE PACKAGE, 8 m, combined gas- and water-cooled

1.3.2006

OPEN WELD HEADS

TORCH BRACKETS, MANUAL TIG HOSE PACKAGE



Item number

TIG TORCH BRACKET (isolator)



'MINI' TORCH BRACKET FOR OSW 40

1.3.1617

Orbital
welding systems



'MINI' TORCH BRACKET, CAN BE SCREWED IN 45°, FOR OSW 40

1.3.1609

Welding
tools



MULTI-POSITION TORCH BRACKET FOR OSW 80 - 170

1.3.1635

Welding
accessories



TORCH BRACKET WITH ROLL SCANNING FOR OSW 80 - 275

1.3.1640

Joint
preparation



HIGH-FLEX MANUAL TIG HOSE PACKAGE, SR 9.8 m, gas-cooled

1.3.1909

- High-flex hose package
- Torch consumables as for OSW
- 5-pin Tuchel plug

Water-cooled version available on request.

Purging
accessories

Measuring
devices

Service /
general

ADAPTATION TO COMPETITOR PRODUCTS



ARC MACHINES, POLYSOUDE, ORBITALUM, SWAGELOK / CAJON, ...

Item number

Most of our welding tools can be adapted to competitor products from the likes of Arc Machines, Polysoude, Orbitalum or Swagelok / Cajon. To some extent, other providers' weld heads can also be connected to Orbitec welding systems using adaptations. The relevant adaptations are available for purchase and for rental.

COMPETITOR PRODUCT ADAPTATION FOR ORBITEC WELD HEADS

OSK C HANDLE AND CABLE ASSEMBLY , AMI version, 8 m	1.3.5311
OSK CW HANDLE AND CABLE ASSEMBLY , AMI version, 8 m	1.3.5315
OSK S HANDLE AND CABLE ASSEMBLY , AMI version, 8 m	1.3.5313
OSK SW HANDLE AND CABLE ASSEMBLY , AMI version, 8 m	1.3.5314
OSK C HANDLE AND CABLE ASSEMBLY , Orbitalum version incl. remote control	1.3.5318
OSK CW HANDLE AND CABLE ASSEMBLY , Orbitalum version incl. remote control	1.3.5319
OSK S HANDLE AND CABLE ASSEMBLY , Orbitalum version incl. remote control	1.3.5305
OSK SW HANDLE AND CABLE ASSEMBLY , Orbitalum version incl. remote control	1.3.5306
POLYSOUDE ADAPTER FOR ORBITEC OSK WELD HEAD , gas-cooled	1.3.5301
POLYSOUDE ADAPTER FOR ORBITEC OSK WELD HEAD , water-cooled	1.3.5302
POLYSOUDE ADAPTER FOR ORBITEC OSW WELD HEAD , gas-cooled	1.3.5303
POLYSOUDE ADAPTER FOR ORBITEC OSW WELD HEAD , water-cooled	1.3.5304

ADAPTATION OF COMPETITOR WELD HEADS TO ORBITEC CONTROLLERS

ORBITEC ADAPTER FOR POLYSOUDE WELD HEAD	1.3.5309
ORBITEC EVO ADAPTER FOR AMI WELD HEAD , gas-cooled	1.3.5316
ORBITEC EVO ADAPTER FOR AMI WELD HEAD , gas- and water-cooled	1.3.5317
ORBITEC EVO ADAPTER FOR ORBITALUM WELD HEAD	1.3.5320
ORBITEC EVO ADAPTER FOR SWAGELOG / CAJON WELD HEAD	1.3.5312

Other adaptations available on request.